

RIGHT HAND CONTROLS SHOWN
VIEW A-A
SCALE 1/50

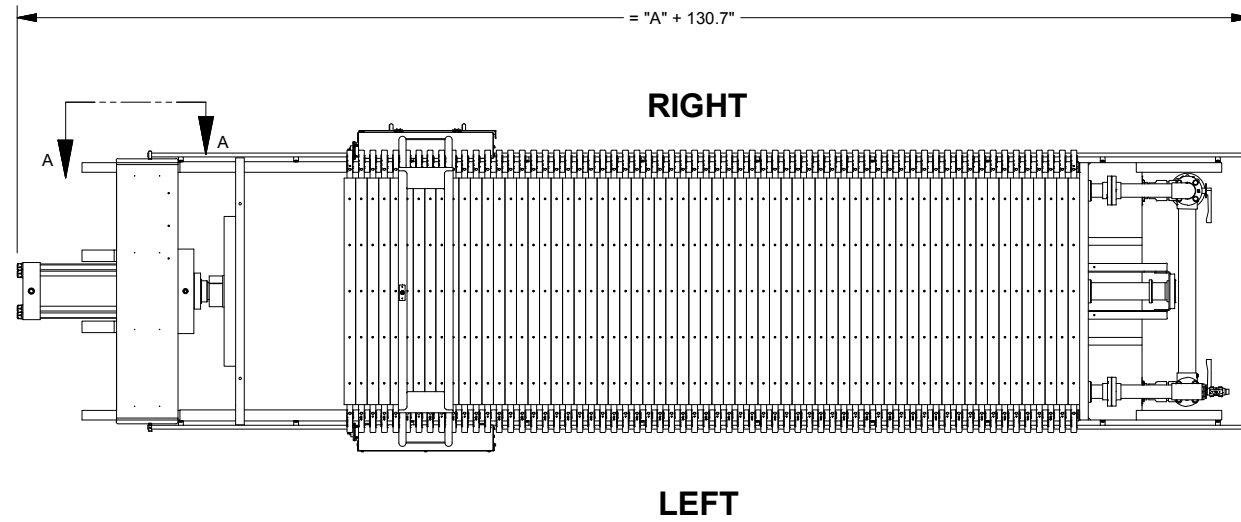

RIGHT

LEFT

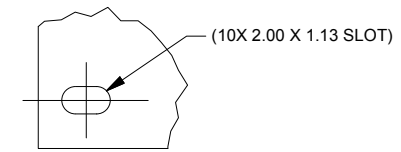
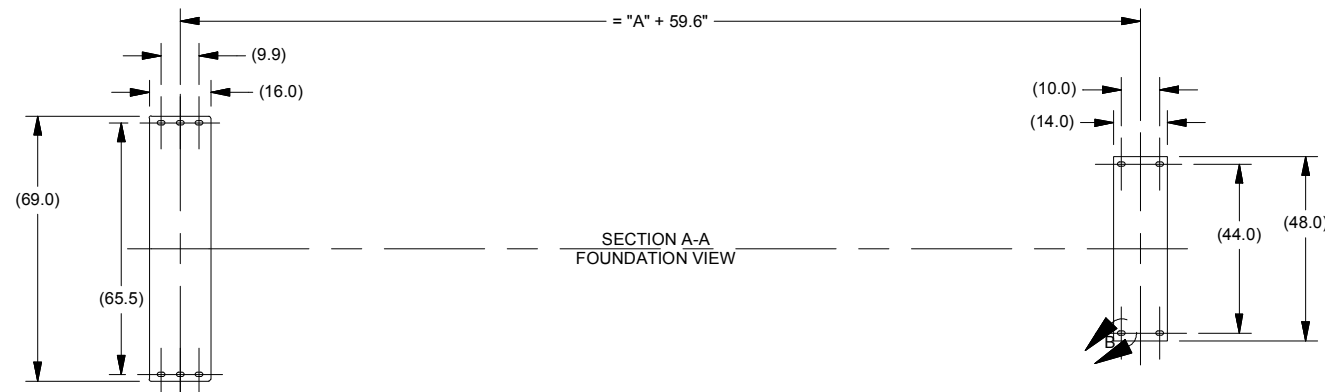
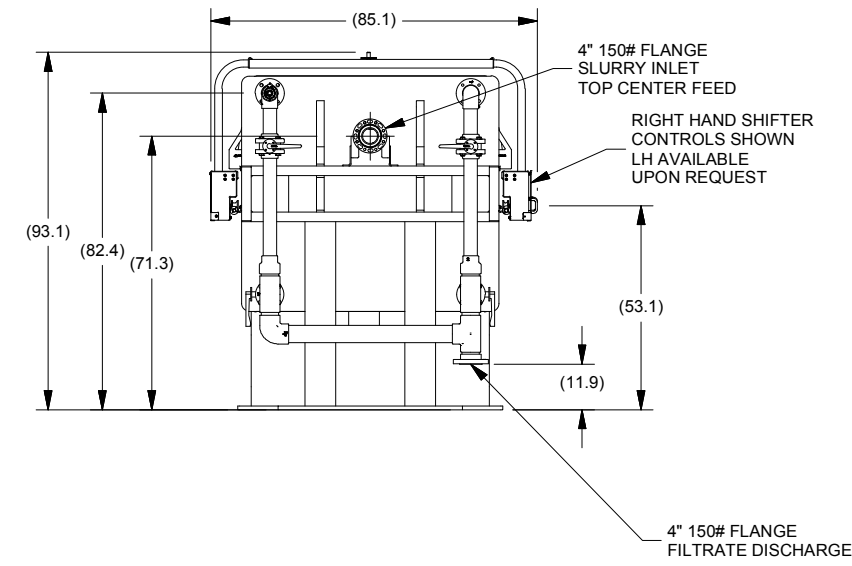
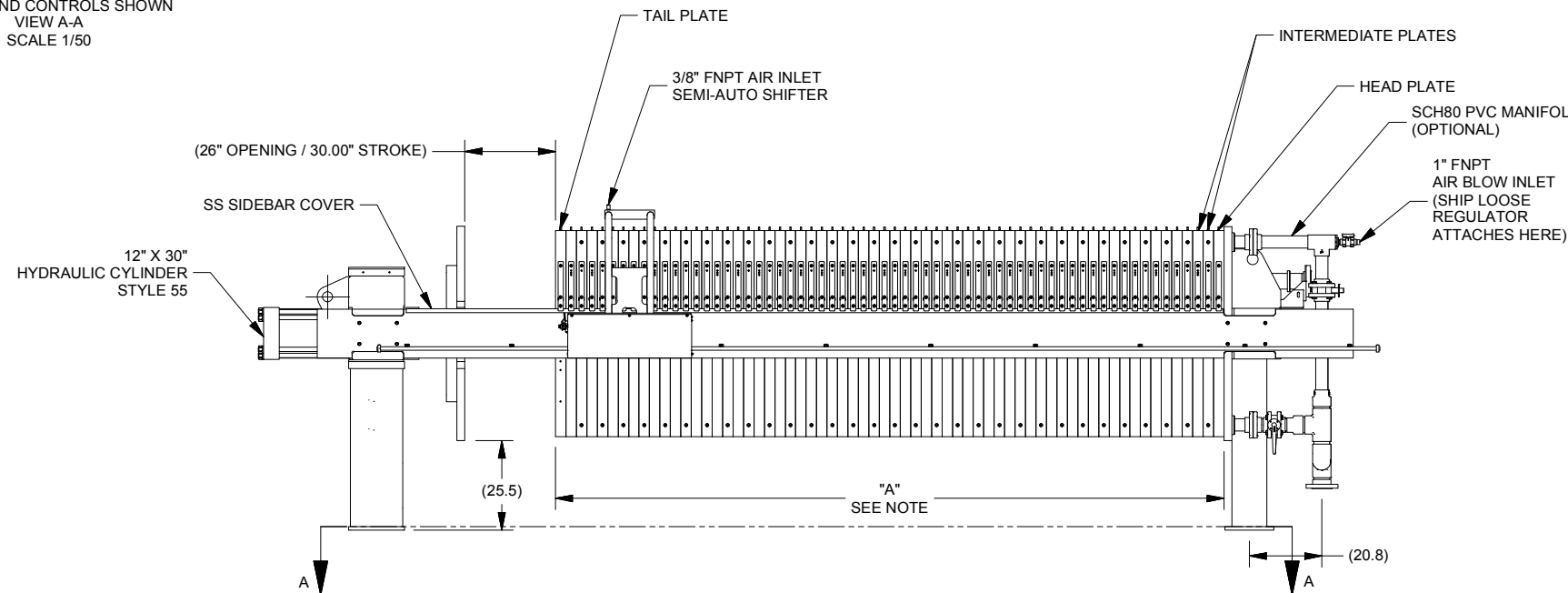
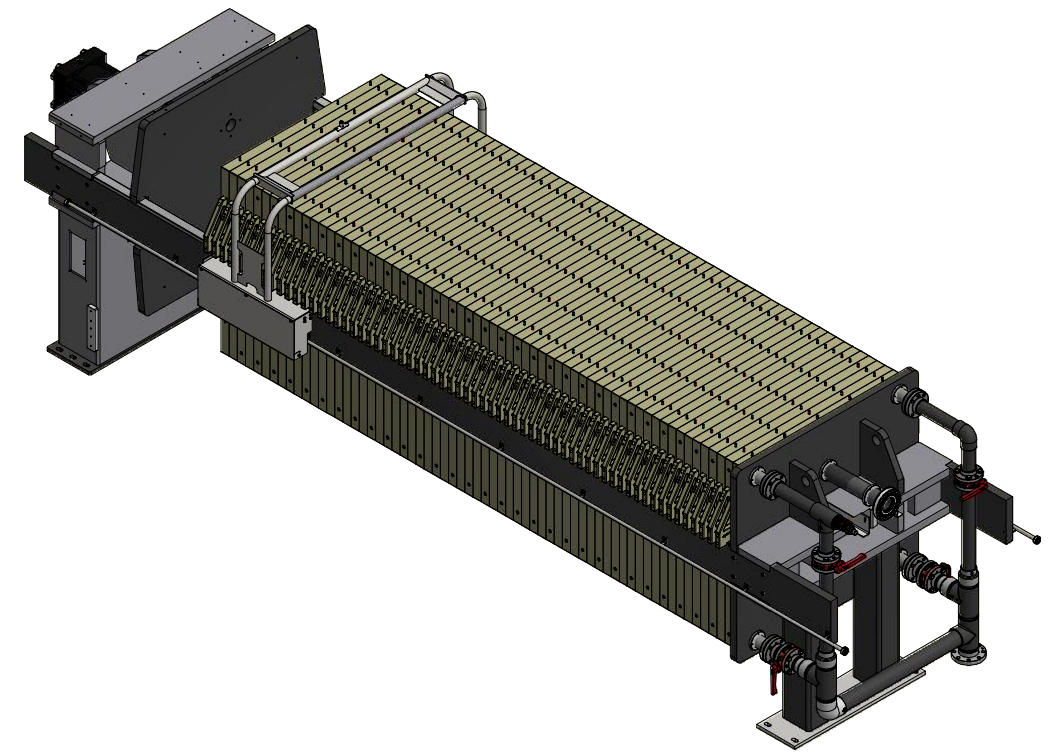

DETAIL B
SCALE 1/8

DRAWING FOR REFERENCE ONLY

NOTE:
"A" DIMENSION INCLUDES PLATE STACK &
OPTIONAL EXPANSION PIECE

DRAWING TOLERANCE ± 1.00

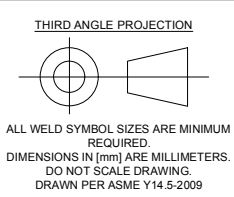

UNLESS OTHERWISE SPECIFIED ALL DIMENSIONS ARE IN INCHES AND TOLERANCES TO BE AS FOLLOWS.

FABRICATION	MACHINE
XX ± .06	XX ± .03
[X ± 2]	XXX ± .005
< ± 2	[X ± 1]
	[X ± .1]
	< ± 1"

REV	DESCRIPTION	DATE	BY	ECN	REV	DESCRIPTION	DATE	BY	ECN
C	UPDATED DRAWING TO CURRENT STANDARDS	11/03/17	JJB						
B	UPDATED LEG CENTER AND OVERAL DIMENSIONS	4/18/13	DAM						
A	INFORMATION ONLY	7/31/12	DAM						

COMPANY CONFIDENTIAL
THIS DOCUMENT AND ALL INFORMATION CONTAINED HEREIN ARE THE PROPERTY OF MW WATERMARK AND/OR ITS AFFILIATES. THE DESIGN CONCEPTS AND INFORMATION CONTAINED HEREIN ARE PROPRIETARY TO MW WATERMARK AND ARE SUBMITTED IN CONFIDENCE. THEY ARE NOT TRANSFERABLE AND MUST BE USED ONLY FOR THE PURPOSE FOR WHICH THE DOCUMENT IS EXPRESSLY LOANED. THEY MUST NOT BE DISCLOSED, REPRODUCED, LOANED OR USED IN ANY OTHER MANNER WITHOUT THE EXPRESS WRITTEN CONSENT OF MW WATERMARK. WHOEVER SHALL BE USED IN ANY MANNER DETRIMENTAL TO THE INTEREST OF MW WATERMARK, ALL PATENT RIGHTS ARE RESERVED. UPON THE DEMAND OF MW WATERMARK, THIS DOCUMENT, ALONG WITH ALL COPIES AND EXTRACTS, AND ALL RELATED NOTES AND ANALYSES, MUST BE RETURNED TO MW WATERMARK OR DESTROYED, AS INSTRUCTED BY MW WATERMARK. ACCEPTANCE OF THE DELIVERY OF THIS DOCUMENT CONSTITUTES AGREEMENT TO THESE TERMS AND CONDITIONS.

DWG BY TMZ	DATE 7/11/2012	TITLE DRAWING SPECIFICATIONS FOR FP1500-SEMI-AS
CKD BY	DATE	CLIENT
FILE: 40010647.idw	SALES ORDER NUM:	 mwwatermark.com
SCALE: NONE	SERIAL NUMBER 40010647	
		REV C