

### NON-GASKETED FILTER CLOTH QUESTIONNAIRE

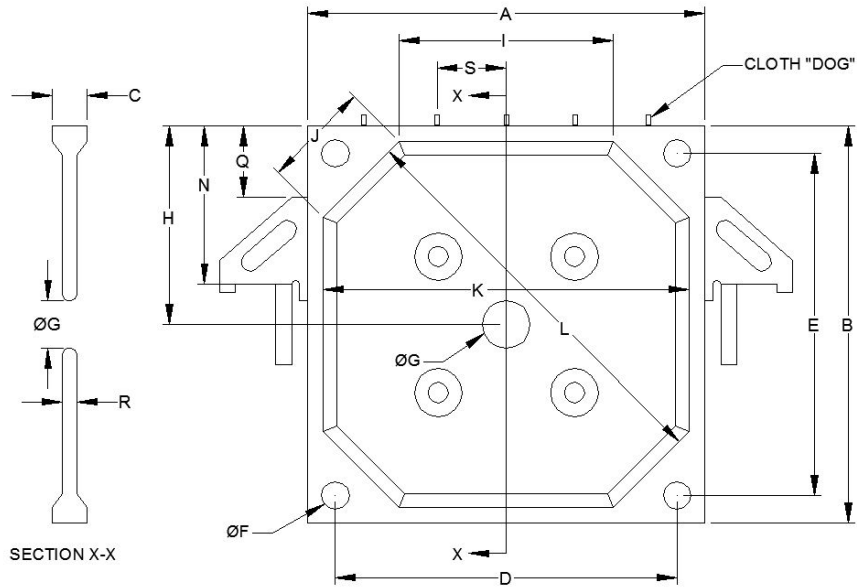

Dim	Description	Metric (mm)	Imperial (inch)
A	Plate Width		
B	Plate Height		
C	Plate Thickness		
D	Corner Hole Horizontal Center to Center Distance		
E	Corner Hole Vertical Center to Center Distance		
F	Corner Hole Inside Diameter		
G	Feed Hole Diameter    Select One: <input type="checkbox"/> Corner <input type="checkbox"/> Center		
H	Feed Hole Distance to Top of Plate		
I	Groove Horizontal Segment Outside Edge to Outside Edge Distance		
J	Groove Diagonal Segment Outside Edge to Outside Edge Distance		
K	Chamber Horizontal Width		
L	Diagonal Chamber Distance		
N	Handle Distance to Top of Plate		
Q	Handle Distance to Top of Plate		
R	Plate Web Thickness		
S	Cloth Dog Center to Center    No. of Cloth Dogs _____		

Please enter contact information below:	
Company:	
Contact Name:	
Telephone:	
Email:	
Address:	
City / State / ZIP:	

Enter filter press information below:	
T	Press Make:
U	Feed Pressure:
V	Cake Thickness:
Y	Cloth Material:
Latex Edge: <input type="checkbox"/> Yes <input type="checkbox"/> No	
Cloth Qty Intermediate:	
Cloth Qty End:	