

## FEATURES

- Standard Models From 5 to 400 GPM
- No Moving Parts
- High Efficiency
- Compact Size Minimizes Floor Space Requirements
- Integral Flash Mixing and Flocculation Tanks
- Heavy duty 1/4" Steel Construction, Welds Are Dye Penetrant Tested
- 1/4" PVC Removable Settling Plates
- Dual Sludge Outlet Flanges
- Large Side-Access Hatch
- Sludge Sampling Ports
- Structure is Sandblasted and Two Coats of Epoxy (Interior) and One Coat of Polyurethane (Exterior) Are Applied to Ensure Full Coverage
- Superior Chemical Resistance

## OPTIONS

- Mixers For Flash & Flocculation Tanks
- Operator Access Platforms
- Custom Designs Available

## PRODUCT RANGE

Model	SPC 5	SPC 10	SPC 20	SPC 40	SPC 80	SPC 150	SPC 200	SPC 300	SPC 400
Design Flow Maximum (GPM)	5	10	20	40	80	150	200	300	400
Flash Mix Tank Volume (gal)	4.4	4.5	38	50	79	110	110	186	186
Flocculation Tank Volume (gal)	6.5	20.5	62	99	189	316	316	742	742
Total Pre-Treatment Volume (gal)	10.9	25	100	149	268	426	426	928	928
Effluent Piping Connection (Class 150 Flange)	2"	3"	4"	4"	4"	6"	6"	8"	8"
Solids Discharge Connection (Class 150 Flange)	2"	3"	4"	4"	4"	4"	4"	6"	6"
Sludge Capacity (gallons)	17	42	88	150	275	469	611	834	960
Plate Area (ft <sup>2</sup> )	19	38	91	198	345	728	1153	1139	1633
Projected Plate Area (ft <sup>2</sup> )	8.9	20	49	107	189	400	633	747	911
Empty Shipping Weight (lb)	765	1400	2065	3600	4800	7400	11000	11800	16500
Full Operating Weigh (lb)	1325	2875	5310	9000	15480	22900	32760	56550	60320
Liquid Volume (gal)	67	177	389	648	1280	1859	2609	5366	5900
Overall Length	45"	56"	70"	87"	104"	135"	163"	179"	210"
Overall Width	23"	44"	60"	60"	73"	77"	77"	90"	100"
Overall Height	51"	64"	94"	104"	129"	147"	147"	147"	143"
Design Solids Removal (200ppm influent)	95%+	95%+	95%+	95%+	95%+	95%+	95%+	95%+	95%+

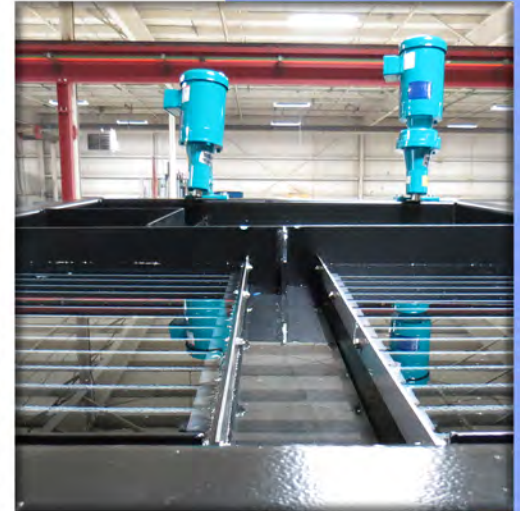



## DESIGN AND USAGE

Influent is fed into the top of the clarifier (A) and flows under a baffle to the integral flash mixing tank (B). The flash mix tank is where coagulants or flocculant would be added if the optional high speed mixer is selected.

From the flash mix tank, the fluid flows over a baffle into the integral flocculation tank (C), which may include an optional low speed mixer.

From the flocculation tank, the fluid flows downward through the feed channel between the two plate stacks to the sludge chamber at the bottom of the clarifier.

At this point the fluid velocity decreases and particles begin to drop out of suspension.

The flow then enters the bottom of the plate stacks and flows upward between the settling plates. Between the plates, the fluid has a non-turbulent laminar flow profile which encourages solids to settle on the surface of the plates downward to the sludge chamber while the fluid flows upward between the plates. The fluid flows over the effluent weirs into the discharge trough. Clarified effluent is then discharged through a flanged pipe connection at the bottom of the trough.

Sludge is periodically pumped from the sludge chamber at the bottom of the clarifier, typically to a larger sludge holding tank, for further treatment by dewatering equipment such as an M.W. Watermark Filter Press. Sample ports are provided in the sludge chamber to help determine the sludge blanket level and set the sludge pump flow rate and pump run/idle times.

Fig. 1a - Top View

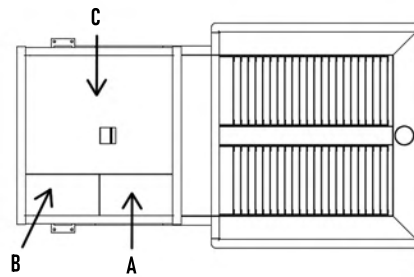

Fig. 1b - Isometric View

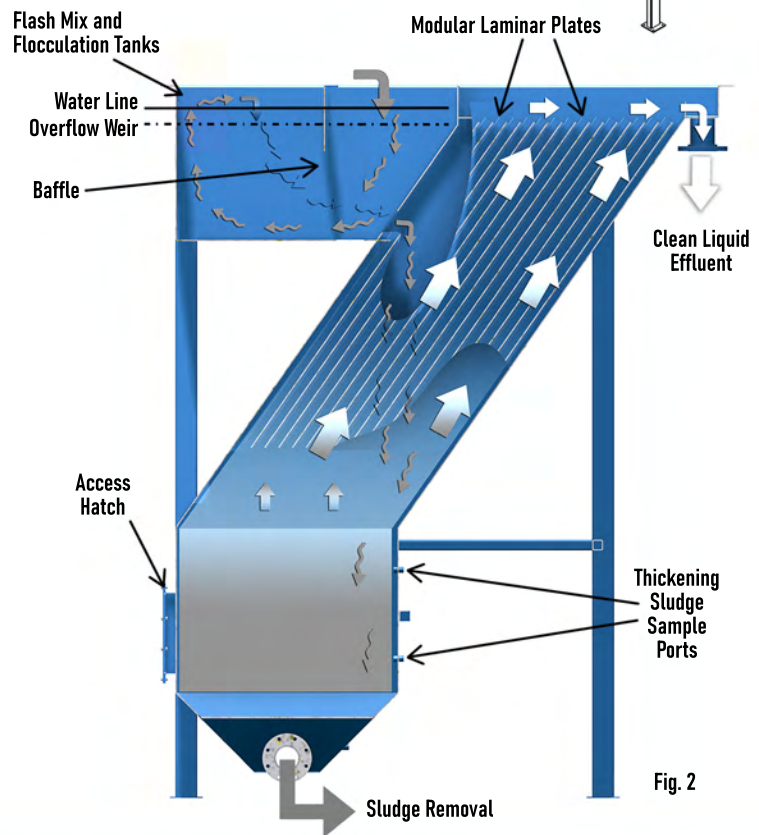
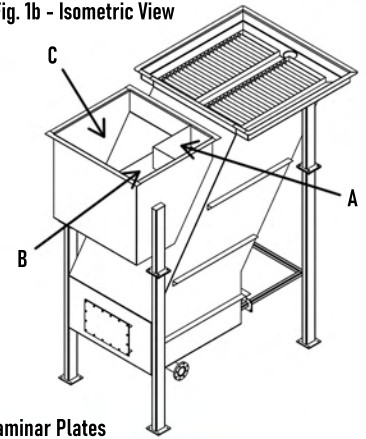
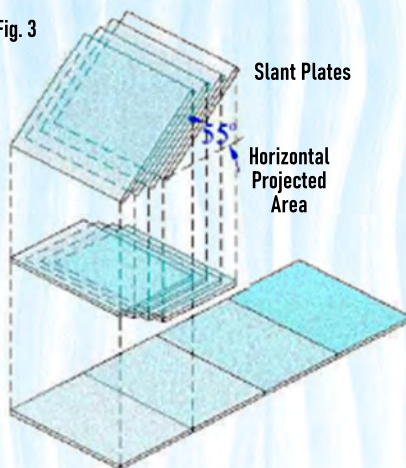

Fig. 3



### Floor Space Requirement Horizontal vs. Slant Plate Clarifier

M.W. Watermark Slant Plate Clarifiers are designed to provide efficient solids removal from a wide range of waste and process liquids. The settling plates are inclined at an angle of 55° with 2-inch spacing. The slope of the plates allows the solids to settle by gravity while the fluid moves upward through the plate stack.

Stacking the plates reduces the floor space required by the clarifier compared to a horizontal clarifier. The inclined plate design allows the total gravity settling area to be as much as ten times the floor space occupied by the clarifier.