

Low Profile Clarifier (LPC) 8 Series

Features

- ✦ Standard models up to 1,100 GPM
- ✦ Compact size minimizes floor space requirements
- ✦ Heavy duty steel construction, welds are dye penetrant tested
- ✦ Carbon steel units are sandblasted and two coats of epoxy applied to ensure full coverage and superior chemical resistance
- ✦ 1/8" polypropylene plates standard
- ✦ Dual sludge outlet flanges
- ✦ Access hatches standard

Options

- ✦ Chemical Addition Tanks - chemical pre-treatment for optimal solids removal Tanks include mixers, chemical pumps and NEMA 4X UL-508A labeled panel
- ✦ Influent feed, sludge discharge and effluent pumps
- ✦ Custom designs available
- ✦ PolyMark™ polymer delivery systems

M.W. Watermark™

M.W. Watermark™ is a leading supplier of water and wastewater equipment, parts, and service. We serve both industrial and municipal markets globally.

Our team strives to provide unmatched service and value to customers, helping reduce their costs while keeping the environment clean.

Ideally suited for

- Industrial wastewater solids
- Metal finishing operations
- Mining industry fines
- Chemical processing
- Foundries
- Power plants
- Process water clarification
- Steel & aluminum plants
- Air scrubbers
- Automotive
- Steel mills
- Wash operations



High efficiency in a compact footprint!

| LOW PROFILE CLARIFIER (LPC) DATA TABLE | LPC-8-660 | LPC-8-880 | LPC-8-1100 | LPC-8-1320 | LPC-8-1540 | LPC-8-1760 | LPC-8-1980 | LPC-8-2200 | LPC-8-2420 | LPC-8-2860 | LPC-8-3300 |
|---|-----------|-----------|------------|------------|------------|------------|------------|------------|------------|------------|------------|
| Design Flow Maximum (GPM) | 165 | 220 | 300 | 330 | 385 | 440 | 500 | 550 | 630 | 950 | 1,100 |
| Inlet/Outlet Connections (Class 150 Flange) | 6" | 8" | 8" | 10" | 10" | 10" | 12" | 12" | 12" | 14" | 14" |
| Solids Outlet Connection (Class 150 Flange) | 4" | 4" | 4" | 4" | 4" | 4" | 4" | 4" | 4" | 4" | 4" |
| Projected Plate Surface Area (ft ²) | 660 | 880 | 1100 | 1320 | 1540 | 1760 | 1980 | 2200 | 2420 | 2860 | 3300 |
| Empty Shipping Weight (lbs.) | 5,700 | 7000 | 8100 | 9100 | 10,600 | 12,600 | 14,800 | 15,000 | 16,000 | 19,500 | 22,000 |
| Flooded Weight (lbs.) | 29,000 | 38,000 | 47,000 | 56,000 | 65,000 | 74,000 | 83,000 | 92,000 | 100,000 | 120,000 | 140,000 |
| Overall Length | 9'-6" | 9'-6" | 9'-6" | 9'-6" | 9'-6" | 9'-6" | 9'-6" | 9'-6" | 9'-6" | 9'-6" | 9'-6" |
| Overall Width | 6'-1" | 8'-1" | 10'-1" | 12'-1" | 14'-1" | 16'-1" | 18'-1" | 20'-1" | 22'-1" | 26'-1" | 30'-1" |
| Overall Height | 11'-6" | 11'-6" | 11'-6" | 11'-6" | 11'-6" | 11'-6" | 11'-6" | 11'-6" | 11'-6" | 11'-6" | 11'-6" |
| Design Solids Removal (Up to 1,000 mg/l) | 95%+ | 95%+ | 95%+ | 95%+ | 95%+ | 95%+ | 95%+ | 95%+ | 95%+ | 95%+ | 95%+ |

** Removal efficiencies are contingent upon proper chemical make-up prior to the Clarifier. Maximum flow rate varies depending on solids concentrations.

The wastewater enters the inlet chamber through a distribution baffle which disperses the water across the entire width of the tank. The inlet chamber reduces the velocities and turbulence in the water. Flow exits the bottom of the chamber into the sludge chamber.

From the sludge chamber flow then enters the bottom of the plate stacks and flows between the settling plates. Between each of the plates, the fluid has a low velocity, laminar flow profile which encourages the remaining solids to settle on the surface of the lower plate and flow downward to the sludge holding chamber.

As the solids are settling along the plate surfaces, the fluid is moving upward through the plate stacks, over an adjustable weir and into the effluent trough.

Clarified effluent is then discharged through an effluent flange. Sludge is periodically drawn off the bottom of the sludge holding tank at the bottom of the clarifier.

Sample ports can be provided to assist with determining the sludge level, which is periodically pumped to a batch storage tank for further solid-liquid separation via an M.W. Watermark™ filter press for eventual disposal.

*Floor Space Requirement
Horizontal vs. Slant Plate Clarifier*

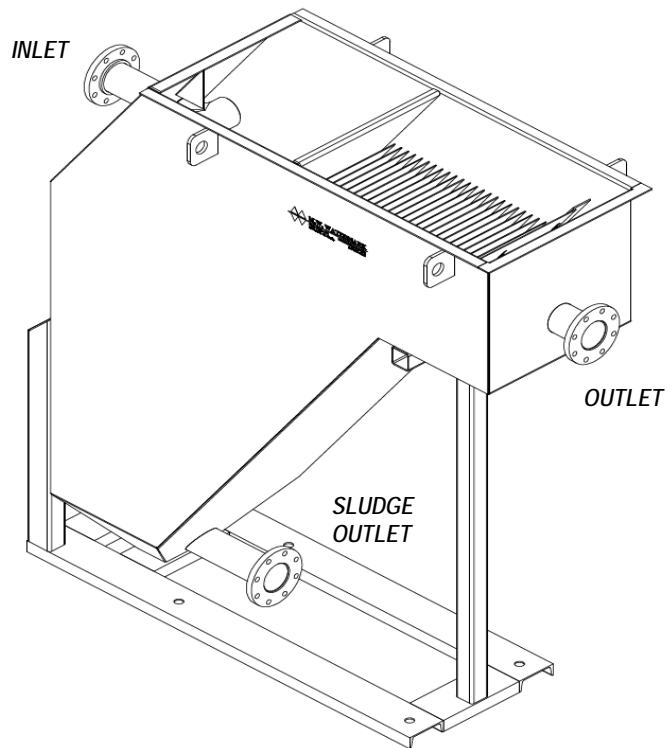
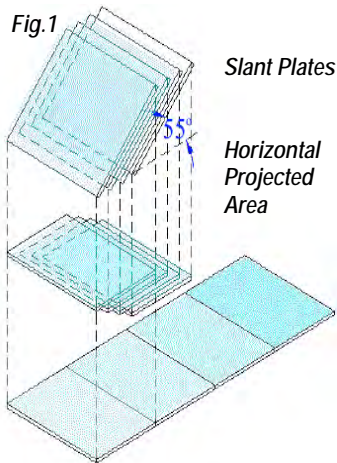

Equipment Design

M.W. Watermark™ low profile clarifiers are designed to provide efficient solids removal from a wide range of waste and process liquids. The settling plates are inclined at an angle of 55° with 1-inch spacing. The slope of the plates allows the solids to settle by gravity while the fluid moves upward through the plate stack.

Stacking the plates reduces the floor space required by the low profile clarifier compared to a horizontal clarifier. The inclined plate design allows the total gravity settling area to be as much as ten times the floor space occupied by the clarifier.

Fig. 1 illustrates the floor space reduction resulting from stacked plates.